

Vortex Flow Meter User Manual



H880TBR Vortex / Swirl Flowmeter

User Manual

1	OVERVIEW.....	1
1.1	TECHNICAL SUPPORT	1
1.2	MAIN SPECIFICATION	1
1.3	FEATURES	1
2	HARDWARE.....	2
2.1	TERMINAL BOARD WIRING.....	2
2.1.1	POWER SUPPLY + EXTERNAL PRESSURE AND TEMPERATURE SENSORS	2
2.1.2	RS485+ PULSE OUTPUT+ EXTERNAL PRESSURE AND TEMPERATURE SENSORS .	3
2.2	SENSOR INTERFACE.....	3
2.2.1	VORTEX SENSOR	3
2.2.2	PRESSURE SENSOR	3
2.2.3	TEMPERATURE SENSOR.....	4
2.3	POWER SUPPLY AND RS485 INTERFACE.....	4
3	LCD DISPLAY	5
4	PRODUCTION PROCESS VIA LOCAL ADJUSTMENT	6
5	DATA ENTRY	7
5.1	BASIC FUNCTION OF KEYS	7
5.2	ENTER OR EXIT MENU MODE.....	7
5.2.1	ENTER MENU MODE	7
5.2.2	EXIT MENU MODE.....	7
5.3	DATA ENTRY METHOD.....	7
5.3.1	'NUMERIC' METHOD.....	7
5.3.2	FROM TABLE METHOD.....	9
5.4	LOCAL CONFIGURATION FUNCTION	9
5.5	TOTALIZER FLOW UNIT TABLE	13
6	PARAMETER DESCRIPTION.....	13
6.1	K- FACTOR	13
6.2	FIVE-POINT LINEARITY CORRECTION	13
6.3	PULSE FACTOR DESCRIPTION	14
6.4	OUTPUT ORIGINAL PULSES DESCRIPTION.....	14

6.5	TEMPERATURE AND PRESSURE COMPENSATION	14
6.5.1	PRECONDITION	14
6.5.2	PRESSURE SENSOR TRIM.....	14
6.5.3	LOW PRESSURE CUTOFF VALUE.....	15
6.5.4	PRESSURE BIAS SETTINGS.....	15
6.5.5	TEMPERATURE SENSOR TRIM.....	15

H880TBR Vortex / Swirl Flowmeter

User Manual

1 Overview

1.1 Technical Support

H880TBR is designed for vortex/swirl flowmeters, which uses piezo sensor.

Please read this manual carefully before use H880TBR. Please follow this manual to complete your operation. If you have any questions, please do not hesitate to contact us. We will reply as soon as possible.

1.2 Main Specification

Power supply: 3.6VDC or 12 - 32VDC
Operating temperature: -20 °C ~ +70 °C(with LCD)
-40 °C ~ +85 °C(without LCD)

1.3 Features

Configuration: Flow mode, Flow unit, Range, Density, Display, etc.

K-Factor linearity: H880TBR provides 2 to 5 points k-Factor correction.

Local adjust functions: Setting range and PV unit, Density, Flow mode, damping, high alarm percent, low alarm percent and data recovery etc.

Two-line LCD display: Instant flow rate and totalized flow value can be displayed simultaneously with high-brightness backlight.

Perfect compensation: H880TBR serials supports real-time temperature and pressure compensation for gas, and supports the international standard of steam density table, temperature and pressure compensation for over heat steam, pressure compensation or temperature compensation for saturated steam.

Restore factory settings: If the damping value entered is '05678', it will automatically perform 'restore factory settings'. (Manufacturers need to perform 'Data Backup' operation.)

Temperature trim: High trim and low trim easily.

Pressure trim: High trim and low trim easily.

H880TBR has a power-down protection and flow accumulation function.

2 Hardware

2.1 Terminal Board Wiring

The terminal board is used for connects the external power supply, output pulse, the external pressure sensor and temperature sensor.

The following are common wiring.

2.1.1 4~20mA output+ HART+pressure sensor

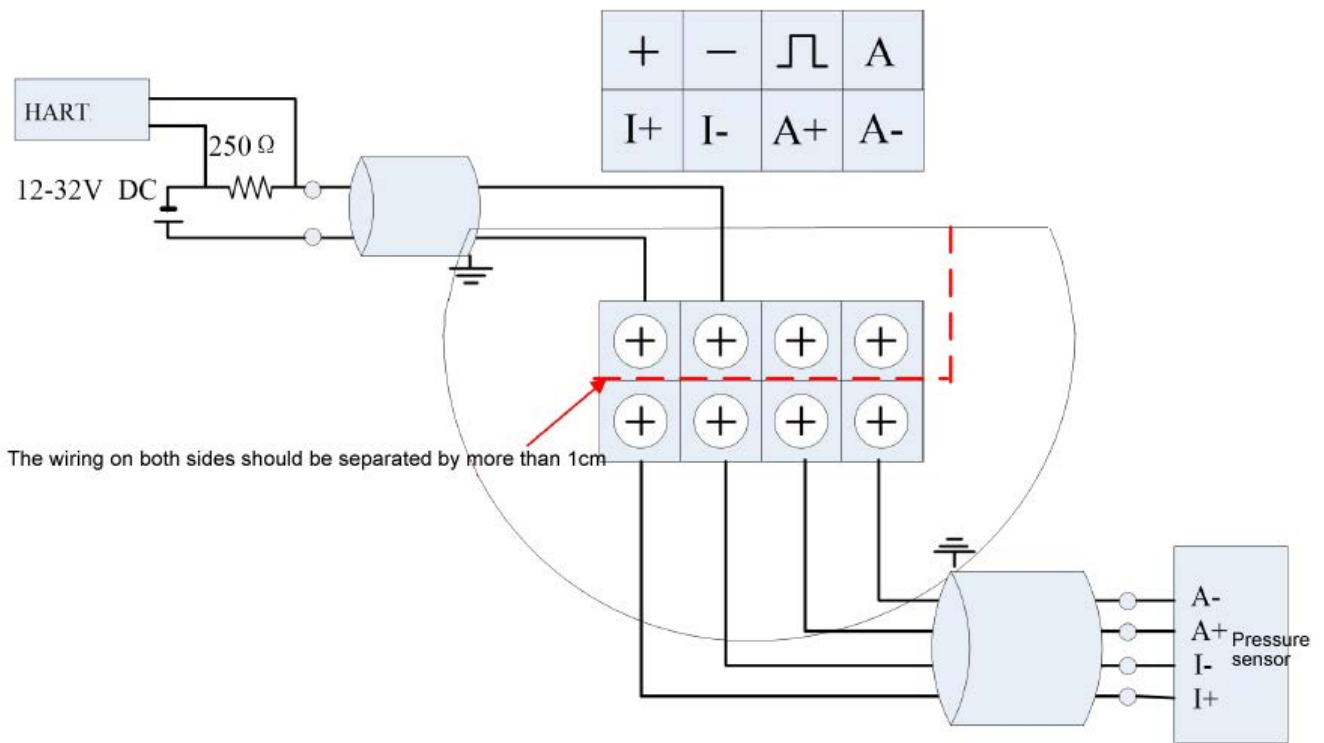

2.1.2 pulse output+pressure sensor

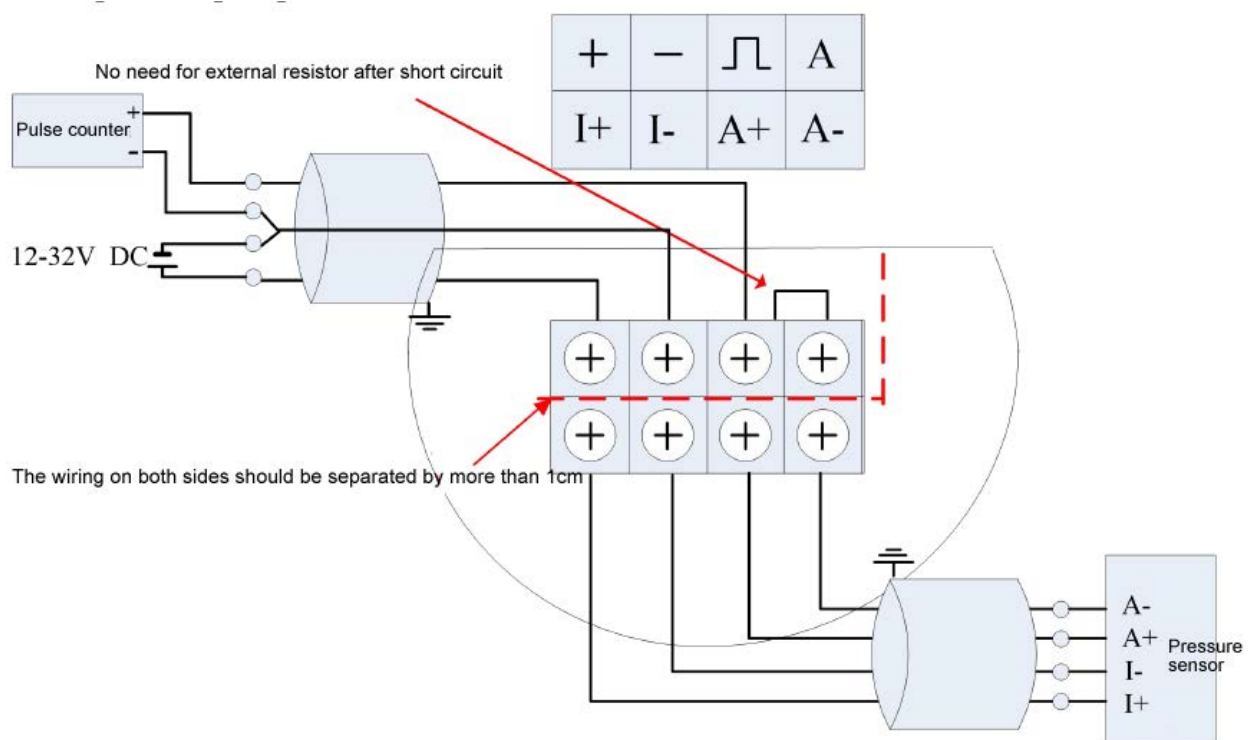

2.1.2 RS485+ Pulse Output+ External Pressure and Temperature sensors

The terminal board H880TDZ-485 can be connected as below with RS485 and pulse output.

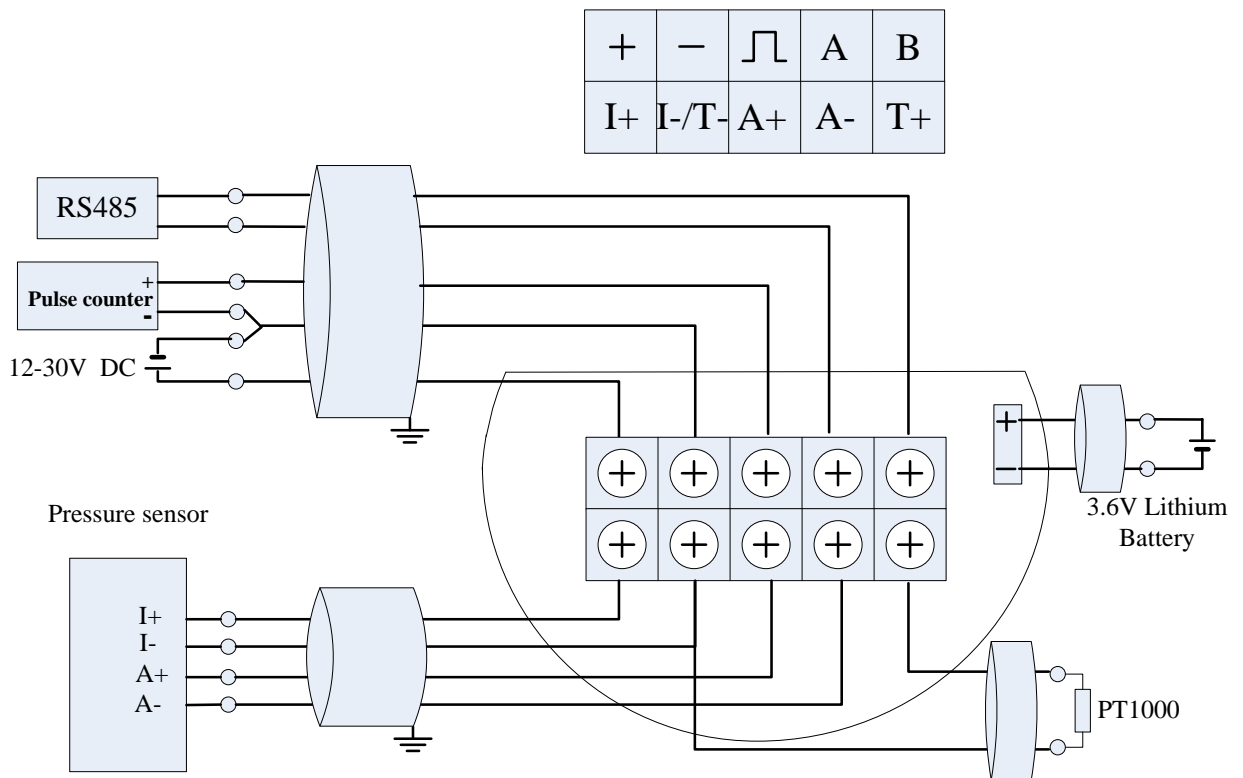

2.2 Sensor Interface

2.2.1 Vortex Sensor

Temperature and pressure compensation vortex flow meter card socket XT [2P green terminal].



2.2.2 Pressure Sensor

Socket XF3 is used to connect pressure sensor. I+ and I- are power supply, A+ and A- are the sensor signal outputs.

The pressure sensor should be bridge type sensors. And the bridge impedance of pressure sensor should be from 3000 to 6000 ohms. The circuit supply about 0.3mA current for the pressure sensor. The pressure sensor can be used, as long as its output does not exceed 50mV@0.3mA..

Socket XF3 is defined as follows.

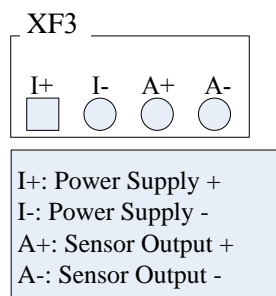

2.2.3 Temperature Sensor

Socket XF5 is used to connect PT1000. It is defined as follows.



Installation Notes: The main circuit board must be reliably connected to housing (Confirm to connect to ground) !

2.3 Power supply and RS485 Interface

Socket XF3 is used to connect power supply and RS485. It is defined as follows.

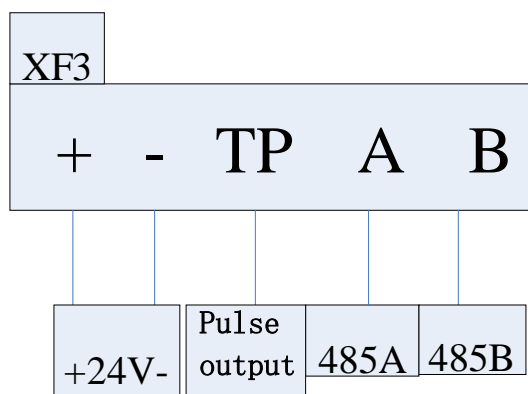

3 LCD Display

LCD Full display is as Figure 3-1:

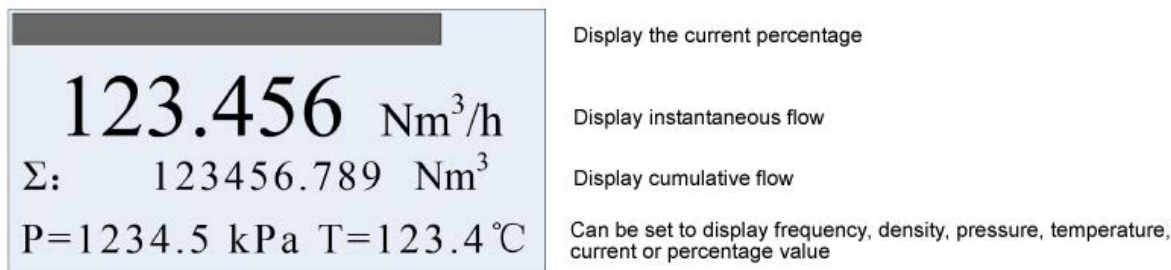
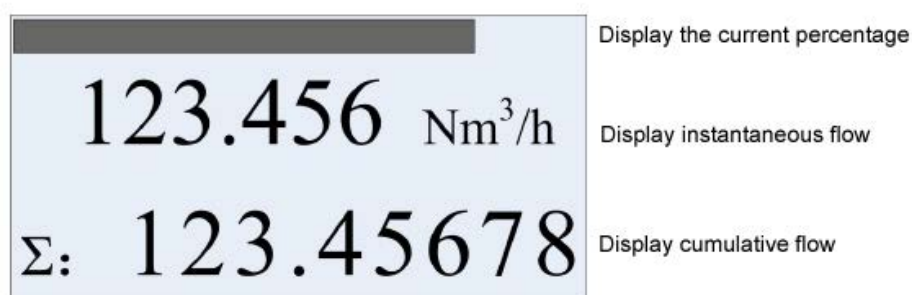

Figure 3-1 LCD Screen

Two-line LCD display. Instant flow rate and totalized flow value can be displayed simultaneously with high-brightness backlight, as Figure 3-2.



Short press M to set the second line display which are the frequency, pressure, temperature, density, current, or percentages.

The following table describes the Prompt and variables.

Prompt	Σ	F:	Den:	P:	T:	Curr:	Per:
variable	totalized flow	frequency	density	pressure	temperature	current	percentage

Notes:



- In write protection mode, display .
- Measured value is lower than the lower limit alarm value, flashing the "down arrow".
- Measured value is higher than the upper limit alarm value, flashing the "up arrow".
- If enable automatic measure pressure, and the pressure signal abnormality (sensor fault), flashing the "left arrow"
- If enable automatic measure temperature, and the temperature signal abnormality (sensor fault), flashing the "right arrow"

4 Production Process via Local Adjustment

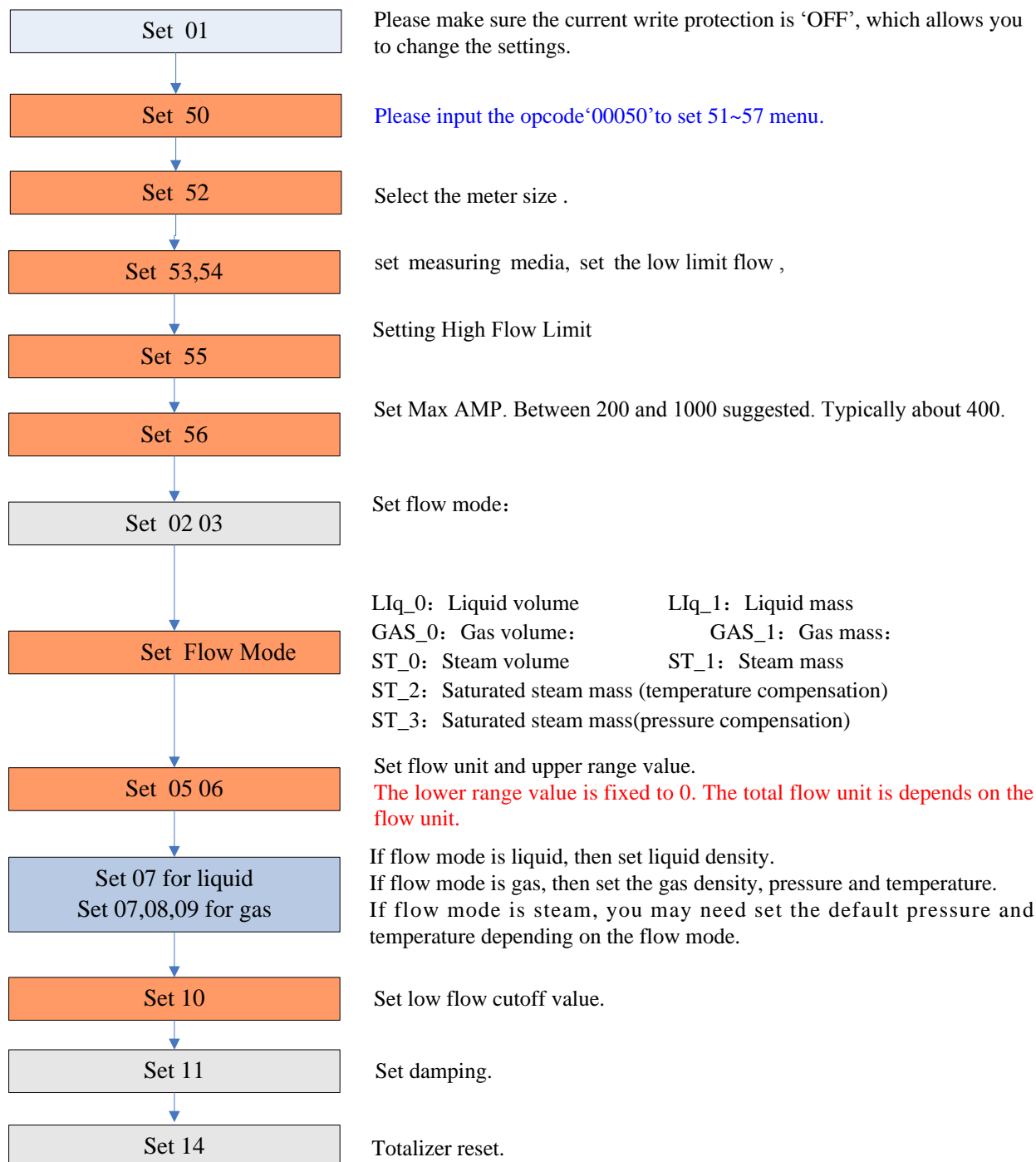
We recommend the following steps to set parameters.



Note:

 This color means that these items must be done.  This color means that these items must be done, and easily be forgotten or be incorrectly set.

5 Data Entry

5.1 Basic Function of Keys

Data is entered using the 3 keys M, S and Z on the display.

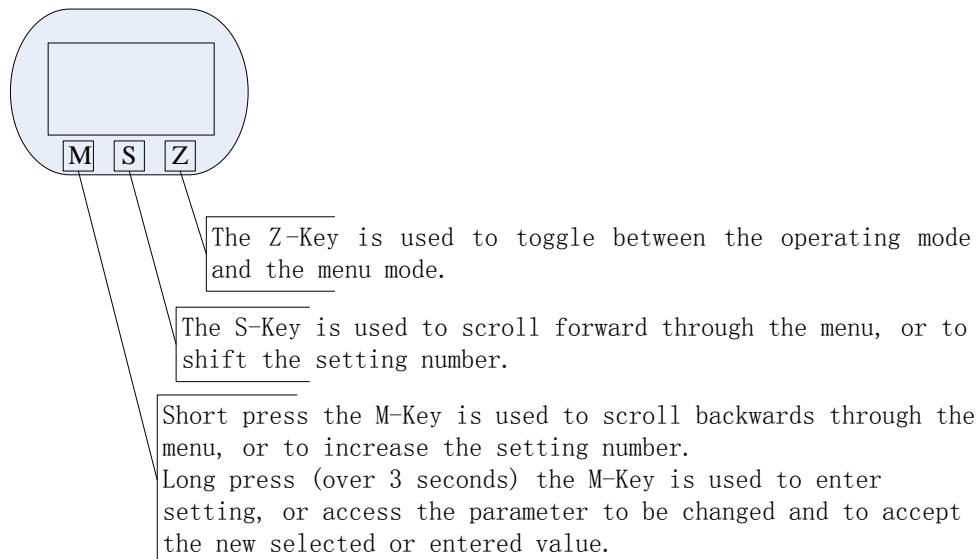

5.2 Enter or Exit Menu Mode

5.2.1 Enter Menu Mode

In the operating mode, press the "Z" key to enter the menu mode (data entry).

5.2.2 Exit Menu Mode

In the menu mode, press the "Z" key to enter the operating mode.

5.3 Data Entry Method

There are two ways to set parameters, one is numeric, and the other is from table .

5.3.1 'Numeric' Method

- Long press the M-Key to enter setting, and the sign flag will start flashing.
- Short press the M-Key to select the sign.
- Press the S-Key to shift the setting number. The number bit will start flashing, which means that you can set. Press M-Key to increase the setting number.
- Press the S-Key to shift the setting number again. All bits can be set according to the same operation.
- After setting all 6-bits, press S-Key to set decimal point position. And five decimal points will flash simultaneously, which means that you can set. Short press M-Key to change the decimal point position.
- After completion of data entry, you can long press M-Key to save (access) the parameter. Or Press Z-Key to give up.

For example, the original range limit is 200, the new input range limit is 400.

<ul style="list-style-type: none"> ➤ Press the Z-key to enter the menu mode. ➤ Press M-Key or S-Key to scroll backwards or forwards the menu ,According to the prompt, Then you can set the range limit. 	<p>Setting the range up limit</p> <div style="border: 1px solid black; padding: 10px; text-align: center;"> <p>Range 100%</p> <p>200.000</p> </div>
<ul style="list-style-type: none"> ➤ Long press the "M" key for more than three seconds to enter the function of setting the upper limit of the range. At this time, there is an underline below the set number to indicate that the setting has been entered. 	<p>Enter setting the range low limit</p> <div style="border: 1px solid black; padding: 10px; text-align: center;"> <p>Range 100%</p> <p><u>2</u>00.000</p> </div>
<ul style="list-style-type: none"> ➤ Press the "M" key at this time to switch between "+" and "-". If "-" is displayed, it means that a negative number will be entered. ➤ After inputting, press and hold the "M" key for three seconds to end the data setting. And save the data into the meter ➤ When inputting data, press the "Z" key to exit the current setting, return to the previous menu, or return to the "normal display" state. ➤ 	

5.3.2 From Table Method

- Long press M-Key to enter setting, and the menu options will start flashing.
- Short press M-Key or S-Key to scroll backwards or forwards the menu.
- Long press M-Key to save (access) the parameter.

5.4 Local Configuration Function

Basic functions (no password required)

Set variable	Menu	Setting method	Notes
01	Write Protect	Long press M key to switch	ON / OFF
02	Low Alarm Limit	numeric	Unit: %
03	High Alarm Limit	numeric	Unit: %
04	Flow mode	from table	LIq_0: Liquid volume LIq_1: Liquid mass GAS_0: Gas volume GAS_1: Gas mass ST_0: Steam volume ST_1: Steam mass ST_2 : Saturated steam mass (temperature compensation) ST_3 : Saturated steam mass (pressure compensation)
05	Flow unit	from table	Nm ³ /h, Nm ³ /m, Nm ³ /s, m ³ /d, m ³ /h, m ³ /m, m ³ /s, l/h, l/m, l/s, t/d, t/h, t/m, kg/d, kg/h, kg/m, kg/s, g/h, g/m, g/s, Note: Totalizer flow's unit based on the flow unit.
06	Range (Qmax)	numeric	Qmax value for selected flow mode (= 20 mA)
07	Density (kg/ m3) Density (g/c m3)	numeric	Gas density (unit: Kg/m3) Liquid density (unit: g/cm3)
08	Gas pressure (Gauge)	numeric	Unit: kpa.
09	Gas temperature (Degrees C)	numeric	Unit: °C.
10	Low flow cutoff value	numeric	Range: 0% ~ 20%
11	Damping	numeric	Range: 0 ~ 64S
14	Total reset	from table	When Lcd display ACC_y, press M-Key to reset the total and overflow counter.
15	Number of total overflows	read only	Display of the number of total overflows; max. 99,999 1 overflow = 10,000,000

40	Trim 4mA		Steps: 1. Long press M-Key, enter trim; 2. Short press M-key to decrease current. Press S-Key to increase current. Stepping is 12 microamperes. 3. Long press M-Key to save new trim value. Or press Z-Key to exit without saving.
41	Trim 20mA		
			Input ****50, set 51~ 57 menu.
50	Opcode	numeric	Input ****40, set 40~ 41 menu. Input ****60, set 60 menu. Input ****62, set 62 menu. Input ****63, set 63 menu. Input ****70, set 70~77 menu. Input***721 ,Set temperature calibration data Input***741 set pressure calibration date
51	Signal status	read only	LCD display: 450.00 51 2 - 10 status: 450.00 is the gain, 51 is indicator, 2 is channel, 10 is signal amplitude, it must be greater than 9.
52	Meter size and media type	from table	Options: 15mm, 20mm, 25mm, 32mm, 40mm, 50mm, 65mm, 80mm, 100mm, 125mm, 150mm, 200mm, 250mm, 300mm, 350mm, 400mm, 450mm, 500mm, 600mm; Note: Maximum frequency, minimum frequency, maximum gain and average calibration K- Factor should be reset, if meter size or media type changed.

53	Fluid Type	from table	Gas Liquid Note: After changing the medium, you must reset the lower limit flow, the maximum magnification, and the meter coefficient (K value). For details, see the "special instructions" at the back of the table
54	Low Flow Limit	numeric	Determined according to the caliber and measuring medium. [The unit is fixed at m3/h (working condition), and the instrument coefficient determines the lower limit of the measurement frequency] The lower limit of actual measurement is about half of the set value.
55	High Flow Limit	numeric	The upper limit flow automatically defaults to 10 times the lower limit flow, and the actual measured upper limit is 2.5 times the set value.
56	Max AMP	numeric	Between 200 and 1000 suggested. Typically about 400.
57	k-Factor	numeric	Set average calibration k-Factor
58	Pulse factor Unit	numeric	Set the output pulse number corresponding 1m3.
59	Pulse Factor	numeric	Enter the number of output pulses corresponding to 1 "Pulse Coefficient Unit". If you want to output the original pulse, set the "meter coefficient (K value)" and "output pulse coefficient" to the same value, and set the "pulse coefficient unit" to m3.
62	Channel settings	from table	There are CH_1, CH_2, CH_3 three options. CH_3 gain maximum CH_1 gain minimum

			<p>Set CH_1 show as follows:</p> <div style="border: 1px solid black; padding: 10px; text-align: center;"> <p>CH_1</p> <p>62</p> </div> <p>Note:</p> <p>CH1 generally used for liquid measurement, which corresponds to the configuration software, select X0 and X1.</p> <p>CH_3 generally used for gas measurement, which corresponds to the configuration software, select X1, X2 and X3.</p>
63	Work mode settings	from table	<p>There are F_1, F_2, F_3, F_4 four options.</p> <p>F_2 setting show as follows:</p> <div style="border: 1px solid black; padding: 10px; text-align: center;"> <p>F_2</p> <p>63</p> </div> <p>Note:</p> <p>Generally choose F_2.</p>
70	Temperature acquisition mode setting	from table	<p>There are t_0 and t_1 two options.</p> <p>t_0: Temperature uses the input reference value. See Section 9: gas temperature.</p> <p>t_1: Temperature is automatic acquisition, should be use external pt1000.</p> <p>t_0 setting show as follows:</p> <div style="border: 1px solid black; padding: 10px; text-align: center;"> <p>t_0</p> <p>70</p> </div>
71	Pressure acquisition mode setting	from table	<p>There are P_0 and P_1 two options.</p> <p>P_0: Pressure uses the input reference value. See Section 8: gas pressure.</p> <p>P_1: Pressure is automatic acquisition, should be use external silicon pressure sensor.</p> <p>P_0 setting show as follows:</p> <div style="border: 1px solid black; padding: 10px; text-align: center;"> <p>P_0</p> <p>71</p> </div>

72	Temperature low trim	numeric	Enter the calibration resistor value, unit: ohm.
73	Temperature high trim	numeric	Enter the calibration resistor value, unit: ohm.
74	Pressure low trim	numeric	Enter the calibration reference pressure value, unit kpa
75	Pressure high trim	numeric	Enter the calibration reference pressure value, unit kpa
76	Low pressure cutoff value	numeric	If the measured pressure value is less than " Low pressure cutoff value", set to 0kpa. Unit kpa.
77	Pressure bias settings	numeric	Enter the current actual pressure value, to achieve bias. Unit kpa.

Special Note:

Maximum frequency, minimum frequency, maximum gain and average calibration K- Factor should be reset, if meter size or media type changed. These parameters are very important for vortex flowmeter good working, please carefully set according to the actual application.

5.5 Totalizer Flow Unit Table

Totalizer flow's unit is determined according to the flow unit.

Flow Unit	Totalizer Flow Unit
Nm ³ /h, Nm ³ /m, Nm ³ /s,	Nm ³
m ³ /d, m ³ /h, m ³ /m, m ³ /s	m ³
l/h, l/m, l/s	l
t/d, t/h, t/m	t
kg/d, kg/h, kg/m, kg/s	kg
g/h, g/m, g/s	g

6 Parameter Description

6.1 K- Factor

The average k-Factor value shown in the display must be the same as the value on the primary tag on the flowmeter primary.

6.2 Five-point Linearity Correction

The actual k-Factor of vortex flowmeter is different in low flowrates and high flowrates. In order to improve the accuracy of vortex flowmeter, it provides 2 to 5 points k-Factor correction.

For example, for D = 80mm, measuring medium is liquid, the real k-Factor in different flowrates as follows:

<20 Hz	40	80	> 100
2200	2100	2100	2000

Then we can choose 4-points calibrated, set k-Factor 2100. Enter the calibration data as follows:

Frequency	k-Factor coefficient	formula
-----------	----------------------	---------

20	0.954545	2100/2200=0.954545
40	1	2100/2100=1
80	1	2100/2100=1
100	1.05	2100/2000=1.05

6.3 Pulse Factor Description

There are two ways to set the pulse factor via HART-CONFIG Tool.

1. Set the number of pulses output every 1m³.
2. Set a pulse corresponds to how many m³.

The output pulses are based on the flow value after five-point K-Factor correction. That will get higher accuracy than using the original pulses.

The local adjustment menu 57 is used to set the output pulse number corresponding 1m³.

6.4 Output Original Pulses Description

If you need the flowmeter outputs original pulses, follow the following steps:

1. Set the K- Factor and the Pulse Factor equal. That is the value of local adjustment menu 56 and 57 equal.
2. Cancel the Five-point linearity correction via HART-CONFIG Tool. Or enter the local adjustment menu 60 to set all of correction coefficient K equal 1.0.

Then the flowmeter output pulse frequency equals to the original pulse frequency.

6.5 Temperature and Pressure Compensation

6.5.1 Precondition

The pressure sensor should be bridge type sensors and the temperature sensor should be PT1000.

User input reference pressure should be gauge pressure, and the unit must be kpa. Absolute pressure and gauge pressure relationship: Absolute pressure = gauge pressure + 101.325kPa.

User should input the reference resistor when trim the temperature sensor.

6.5.2 Pressure Sensor Trim

If you want trim the pressure sensor, please check the flow mode and pressure acquisition mode setting.

character	Menu	Setting
04	Flow mode	Set one of the following: (The other modes do not collect pressure) GAS_0: Gas volume: GAS_1: Gas mass: ST_0: Steam volume ST_1: Steam mass ST_3 : Saturated steam mass(pressure compensation)
71	Pressure acquisition mode setting	P_1: Pressure is automatic acquisition, should be use external silicon pressure sensor.

It provides two points calibration for the pressure sensor. If use HART-CONFIG Tool, please enter into

‘Advanced Features’ -> ‘Temperature and Pressure Sensors’ to trim the sensor.

You can also trim the sensor via local adjustment menu 74 and 75:

1. Set menu 04 and 71.
2. Apply zero pressure to the sensor, enter into menu 74, input the reference pressure(gauge pressure, unit kpa) to trim zero.
3. Apply full pressure to the sensor, enter into menu 75, input the reference pressure(gauge pressure, unit kpa) to trim full.

6.5.3 Low pressure cutoff value

If the pressure value is close to 0 is not stable, for example, varied between -0.01 and 0.01 kPa, may cause the output fluctuation. You can set ‘Low pressure cutoff value’ to remove this fluctuation.

If the measured pressure value is less than ‘Low pressure cutoff value’, it will set to be 0kpa.

6.5.4 Pressure bias settings

If there is a fixed pressure deviation, for example, the actual pressure value is 10kPa and the measured pressure value is 9.8kPa. You can perform ‘7.5.4 Pressure bias settings’ to remove this error.

Enter the current actual pressure value, to achieve bias.

6.5.5 Temperature Sensor Trim

If you want trim the temperature sensor, please check the flow mode and temperature acquisition mode setting.

character	Menu	Setting
04	Flow mode	Set one of the following: (The other modes do not collect temperature) GAS_0: Gas volume: GAS_1: Gas mass: ST_0: Steam volume ST_1: Steam mass ST_2 : Saturated steam mass (temperature compensation)
70	Temperature acquisition mode setting	t_1: Temperature is automatic acquisition, should be use external pt1000.

It provides two points calibration for the temperature sensor. We recommend use 1000ohm and 2500ohm resistors for calibration. If use HART-CONFIG Tool, please enter into ‘Advanced Features’ -> ‘Temperature and Pressure Sensors’ to trim the sensor.

You can also trim the sensor via local adjustment menu 72 and 73:

1. Set menu 04 and 70.
2. Apply lower resistor, such as 1000ohm, enter into menu 72, input the reference resistor value(1000) to trim..
3. Apply higher resistor, such as 2500ohm, enter into menu 73, input the reference resistor value(2500) to trim..